

SPARE PARTS MANUAL: ENGINE

ART.NO.: 3CM080233EN

ENGLISH



INDEX

50 AC 2006

<p>SPECIAL TOOLS</p> <p>HOLZPLATTE - SELBSTGEFERTIGT WOODEN PLATE - HOME MADE</p> <p>2</p>	<p>ENGINE CASE</p> <p>3</p>	<p>CRANKSHAFT, PISTON</p> <p>4</p>	<p>CYLINDER, CYLINDER HEAD</p> <p>5</p>
<p>CARBURETOR</p> <p>6</p>	<p>CLUTCH</p> <p>7</p>	<p>KICKSTARTER</p> <p>8</p>	<p>TRANSMISSION</p> <p>9</p>
<p>IGNITION SYSTEM</p> <p>10</p>	<div style="display: flex; align-items: center;"> <div style="background-color: #ccc; padding: 20px; margin-right: 20px; font-size: 48px; font-weight: bold; text-align: center;">!</div> <div> <p>All information contained is without obligation. KTM-Sportmotorcycle AG particularly reserves the right to modify any equipment, technical specifications, prices, colors, shapes, materials, services, service work, constructions, equipment and the like so as to adapt them to local conditions or to cancel any of the above items, all without previous announcement and without giving reasons. KTM may stop manufacturing certain models without previous notice. KTM shall not be held liable for any deviations of availability and/or ability to deliver, illustrations, descriptions, printing and/or other errors. The illustrated models partly contain extra equipment, which is not applied to standard models. © 2004 by KTM-SPORTMOTORCYCLE AG, Mattighofen AUSTRIA; All rights reserved; Reprint, also in extracts, with written allowance of KTM-SPORTMOTORCYCLE AG, Mattighofen only.</p> </div> </div>		

SPECIAL TOOLS

50 AC 2006

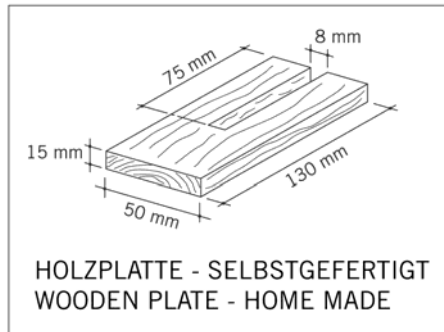
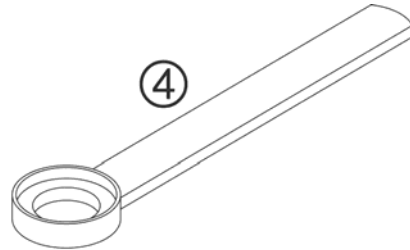
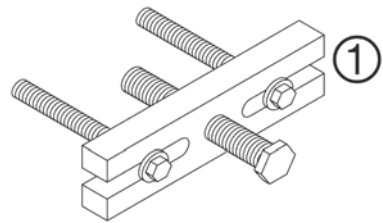

FIG	PART NUMBER	DESCRIPTION	QTY
1	59029021044	EXTRACTOR PRIM. GEAR CPL.	1
2	6899785	LOCTITE 243 BLUE 6CCM	1
4	45112021000	HOLDING SPANNER F. FLYWHEEL 02	1
5	45129006000	ADJUSTING PLATE 50SX MINI 2001	1

2



ENGINE CASE

50 AC 2006

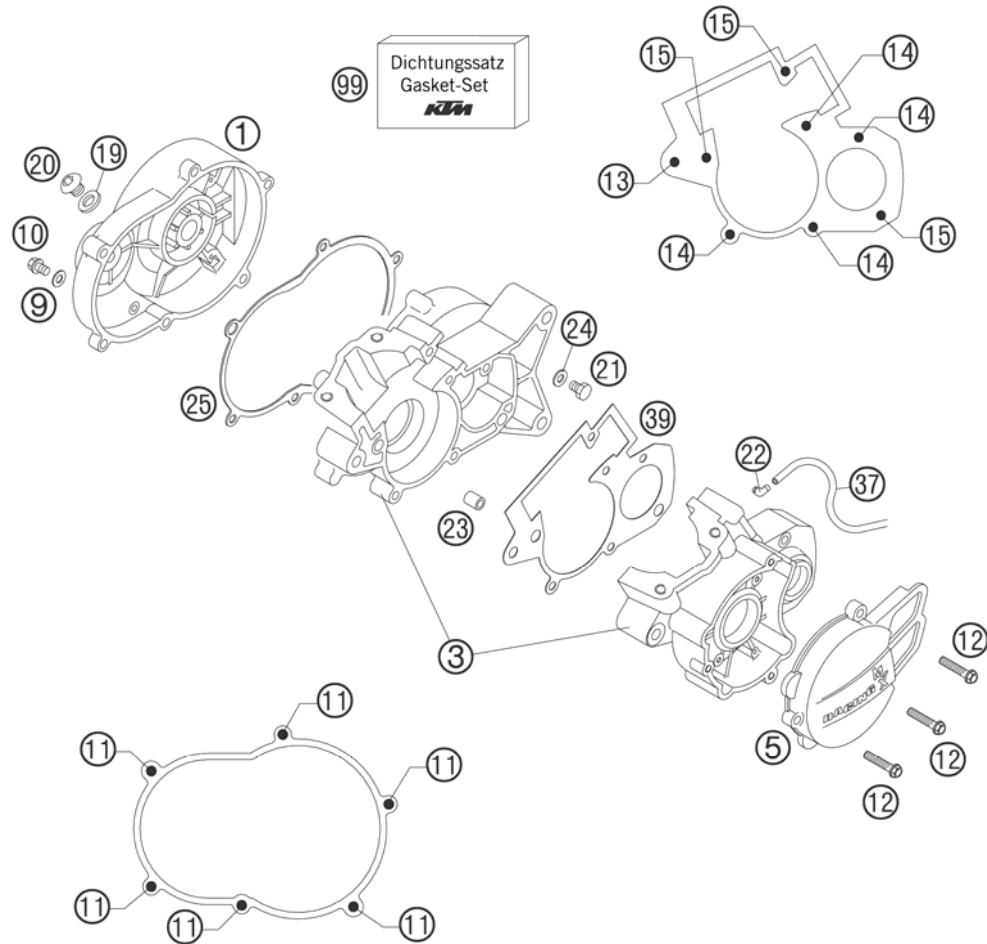

FIG	PART NUMBER	DESCRIPTION	QTY
1	45130001100	CLUTCH COVER 50 2004	1
3	45130000044	ENGINE CASE 50CCM LC 2001	1
5	45130502000	IGNITION COVER 50 AC 2002	1
9	0603061001	CU-SEAL RING DIN7603-6X10X1	1
10	0015060103	HH COLLAR SCREW M 6X10 WS=8	1
11	0015060253	HH COLLAR SCREW M 6X25 WS=8	6
12	0015060303	HH COLLAR SCREW M 6X30 WS=8	3
13	0015080603	HH COLLAR SCREW M 8X60 WS=10	1
14	0912060353	AH SCREW DIN0912-M 6X35	4
15	0912060404	AH SCREW DIN0912-M 6X40 A2	3
19	45130019000	GASKET FOR OIL PLUG	1
20	45130020000	OIL PLUG 50 LC 2001	1
21	46030021100	OIL DRAIN PLUG M10 WS=13	1
22	45130022000	ANGLE PIECE 50CCM LC 2001	1
23	45130023000	DOWEL 7X9X10	4
24	0603100141	COPPER GASKET DIN7603-10X14X1	1
25	45130025000	GASKET FOR CLUTCH COVER 2001	1
37	52031137001	PVC-HOSE 3X5MM	x
39	45130039000	ENGINE CASE GASKET 50 LC 2001	1
99	45130599000	GASKET SET CPL. 50 AC 2002	1

3



CRANKSHAFT, PISTON

50 AC 2006

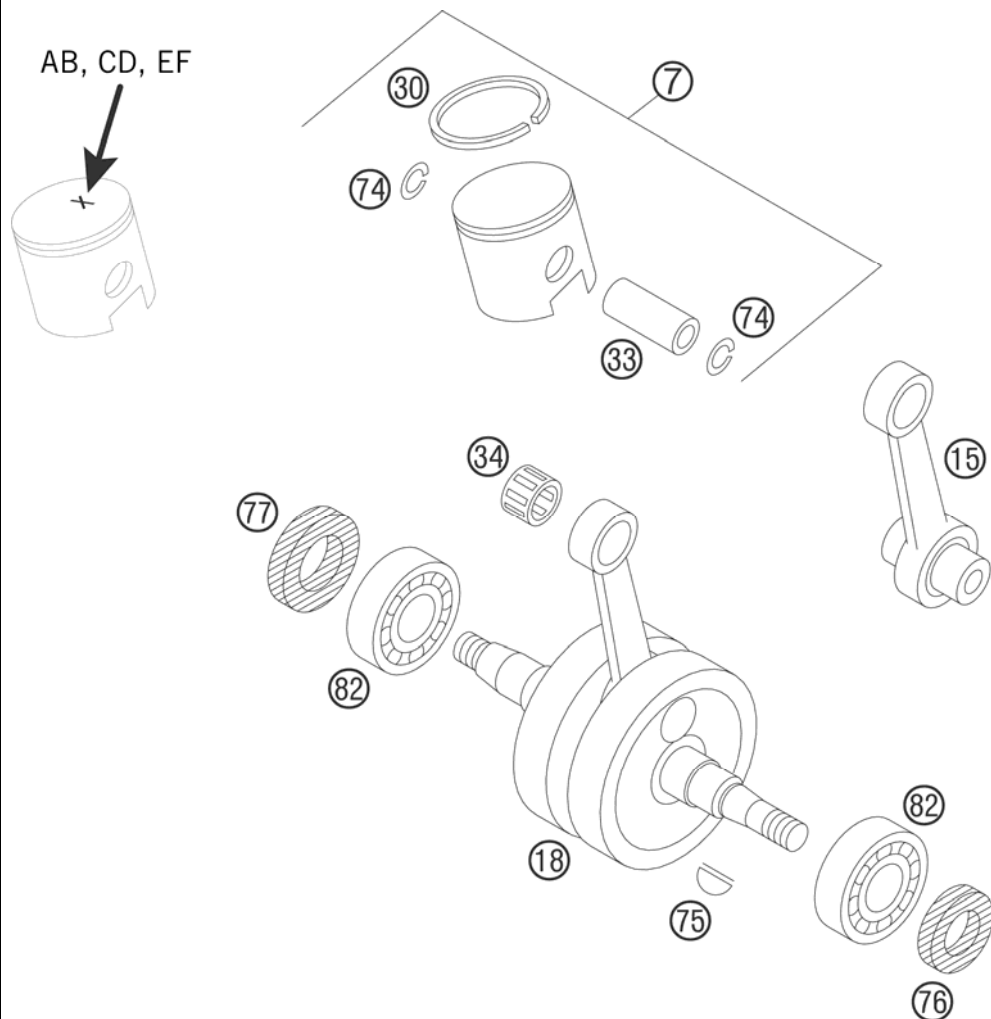

FIG	PART NUMBER	DESCRIPTION	QTY
7	45130007000 A	PISTON CPL.39,5 "AB" 50 LC 01	x
7	45130007000 C	PISTON CPL.39,5 "CD" 50 LC 01	x
7	45130007000 E	PISTON CPL.39,5 "EF" 50 LC 01	x
15	45130515000	CON.ROD REPAIR SET 50 AC 2002	1
18	45130518000	CRANKSHAFT 50 AC 2002	1
		SENIOR ADV.	
30	45130030000	PISTON RING 50CCM LC 2001	1
33	45130033000	PISTON PIN 50CCM LC 2001	1
34	45130034000	NEEDLE BEAR.PISTONPIN 12X15X15	1
74	45130074000	CIRCLIP 2001	2
75	45130075000	WOODRUFF KEY 2,5X3,7	1
76	45130076000	OIL SEAL RING 15X24X7	1
77	45130077000	OIL SEAL RING 17X35X7	1
82	45130082100	BALL BEARING 17X40X12 2002	2

4

KTM**CYLINDER, CYLINDER HEAD****50 AC 2006**

FIG	PART NUMBER	DESCRIPTION	QTY
5	45130505000 A	CYLINDER 39,5MM "A" 50 2002	x
5	45130505000 B	CYLINDER 39,5MM "B" 50 2002	x
5	45130505000 C	CYLINDER 39,5MM "C" 50 2002	x
6	45130506100	CYLINDER HEAD 50 GS 2002	1
7	0015060253	HH COLLAR SCREW M 6X25 WS=8	4
10	0015060203	HH COLLAR SCREW M 6X20 WS=8	2
11	0015080203	HH COLLAR SCREW M 8X20 WS=10	4
12	0125060003	WASHER DIN0125-A 6,4	4
20	10001120000	CLAMP 25-40 SGT 4	1
28	45139028000	BRACKET IGNITI. COIL 50LC 2001	1
29	45139128000	COLLAR BUSHING 6,3X8X7,5	2
30	0015060303	HH COLLAR SCREW M 6X30 WS=8	2
31	0021060003	WASHER DIN9021-A 6,4	2
35	46030035020	CYLINDER BASE GASKET 0,2 MM	x
35	46030035050	CYLINDER BASE GASKET 0,5 MM	x
37	45130537000	CYLINDER HEAD GASKET 50 AC 02	1
49	46030049000	INTAKE VALVE GASKET	1
50	45130050000	INLET MANIFOLD 50CCM LC 2001	1
51	46030051144	MEMBRANE HOUSING CPL.65SX 2001	1
52	46030052000	MEMBRANE LOOSE 60/65 CCM	2
54	0985030063	FLAT HEAD SCREW DIN7985-M 3X6	4
60	31008060000	RUBBER SLEEVE D=8MM OPEN	2
88	45130588000	DAMPING RUBBER-SET 2002	1

5

KTM**CARBURETOR****50 AC 2006**

FIG	PART NUMBER	DESCRIPTION	QTY
1	45131001000	CARBURETOR DELLORTO 14PHVA DS	1
2	0084050163	CYL.HEAD SCREW DIN0084-M 5X16A	1
3	45131527000	CARBURETOR COVER DELLOR. 12-14	1
5	45131530000	SPRING	1
6	45131531000	SPRING CAP	1
7	45131535000	THROTTLE VALVE 40	1
8	45131545000	CLAMP SPRING	1
10	45131534010	JET NEEDLE A10	1
11	45131517000	IDLE ADJUST SCREW	1
12	45131516000	SPRING FOR ADJUST SCREW	1
13	45131548000	STARTING LEVER CPL. DELL.12-14	1
17	45131617000	ADJUST SCREW	1
20	45131536000	ATOMIZER 211FA	1
21	45131023065	MAIN JET 65 DELLORTO	1
21	45131023070	MAIN JET 70 DELLORTO	x
21	57031523080	MAIN JET 80	x
21	59030054000	JET 60 DELLORTO M6X0,75	x
22	45131551060	STARTING JET 60	1
23	45131507035	IDLING JET 35	x
23	45131507038	IDLING JET 38	1
23	45131507045	IDLING JET 45	x
25	45131509000	FLOAT CPL.	1
26	45131511000	FLOAT BOWL DELLORTO 12-14	1
27	0084040203	CYL.SCREW DIN0084-M 4X20 A	2
28	52031137001	PVC-HOSE 3X5MM	x
30	45131599000	GASKET SET DELLORTO 12-14 PHVA	1

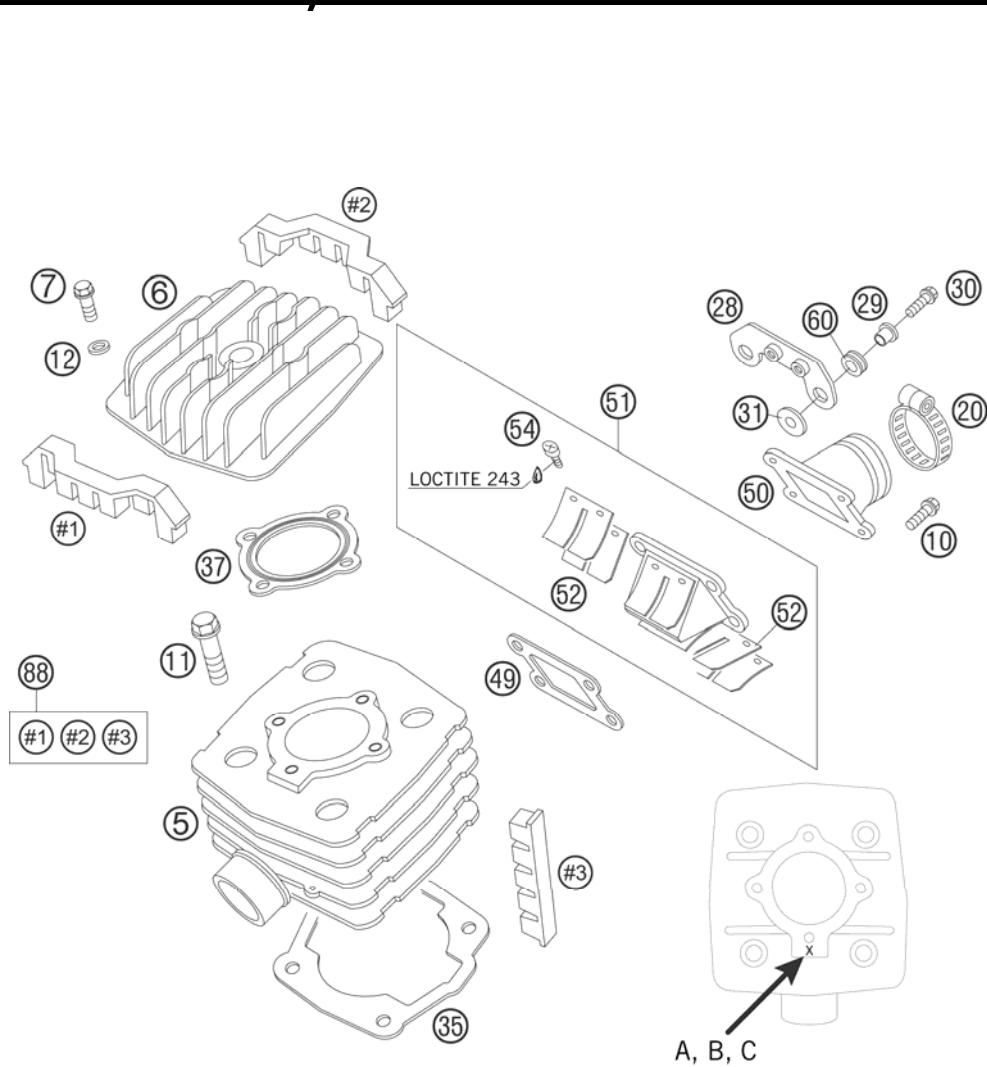

ACHTUNG !!!
Vor dem Einbau des Vergasers, Bedüsung kontrollieren.
CAUTION !!!
Before mounting the carburetor, check the jetting.

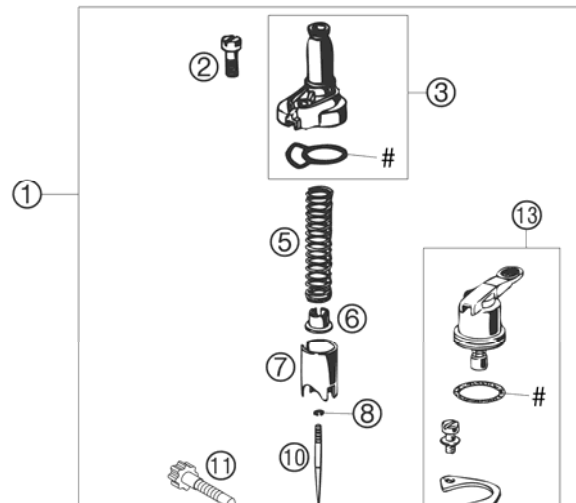

6

KTM**CLUTCH****50 AC 2006**

FIG	PART NUMBER	DESCRIPTION	QTY
2	45132502044	CLUTCH CPL.50 2002	1
3	45132002000	CLUTCH HUB 50 LC 2002	1
4	45132004000	SPACER 6X8X19	3
5	45132005100	CLUTCH SPRING 50 GS 2002	3
7	0933060253	HH SCREW DIN0933-M 6X25	3
11	45132011100	CLUTCH BLOCK 50 LC 2002	3
15	45132015000	NEEDLE BEARING 15X18X17	1
19	45132020060	SPACER WASHER 15X25X0,6	x
19	47033040000	STOP DISC 15X25X1	x
19	47033043000	STOP DISC 15X25X0,5	x
20	45132020000	WASHER 10,4X16,8X0,4	1
21	45132120000	WASHER 8X15,3X0,5	6
23	45132023016	CLUTCH DRUM 16-T	1
30	45130029000	SPECIAL NUT 10X1,25X8	1

7

KTM**KICKSTARTER****50 AC 2006**

FIG	PART NUMBER	DESCRIPTION	QTY
49	0471150010	CIRCLIP DIN0471-15X1	1
51	45133050100	KICKSTARTER SHAFT 50 2004	1
52	45133052000	KICKSTARTER SLEEVE 2001	1
53	45135056000	OIL SEAL RING 16X22X4	1
54	45133054000	KICKSTARTER SPRING 2001	1
56	45133056000	KICKSTARTER SLEEVE SPRING 2001	1
58	45133058000	BEARING BOLT F. KICKST SLEE.01	1
59	47033041000	STOP DISC 16X26X1	1
69	0015060203	HH COLLAR SCREW M 6X20 WS=8	1
70	45133070000	KICKSTARTER 50CCM LC 2001	1

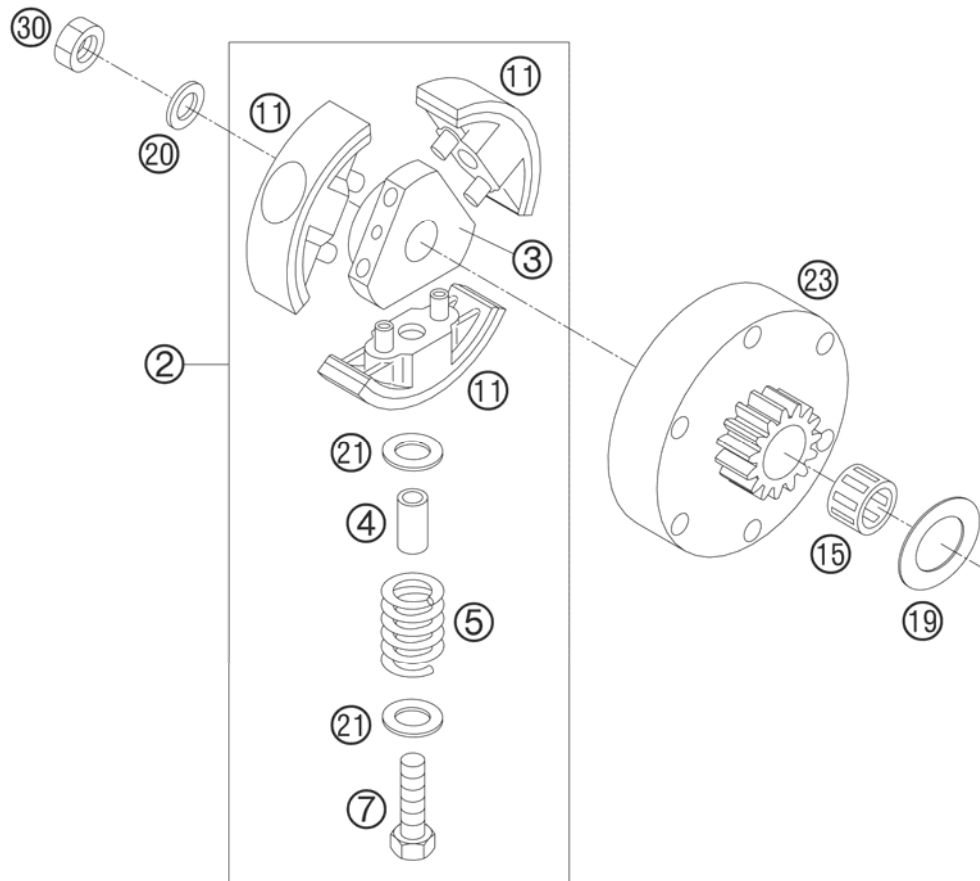
8

KTM**TRANSMISSION****50 AC 2006**

FIG	PART NUMBER	DESCRIPTION	QTY
2	45133002000	COUNTER SHAFT 50CCM LC 2001	1
24	45133024000	WOODRUFF KEY 5X5X12	1
25	45132024057	PRIMARY GEAR 57-T	1
28	45133028000	BALL BEARING 15X35X11	2
29	45133029009	SPROCKET 9-T 50 LC 2001	x
29	45133029010	SPROCKET 10-T 50 LC 2001	x
29	45133029011	SPROCKET 11-T 50 LC 2001	1
29	45133029012	SPROCKET 12-T 50 LC 2001	x
29	45133029013	SPROCKET 13-T 50 LC 2001	x
30	0471150010	CIRCLIP DIN0471-15X1	1
31	45133031000	OIL SEAL RING 15X24X5	1
77	46030029000	HH NUT 14X1,25X7 WS=22	1
78	46030078000	LOCKING PLATE D=14MM	1

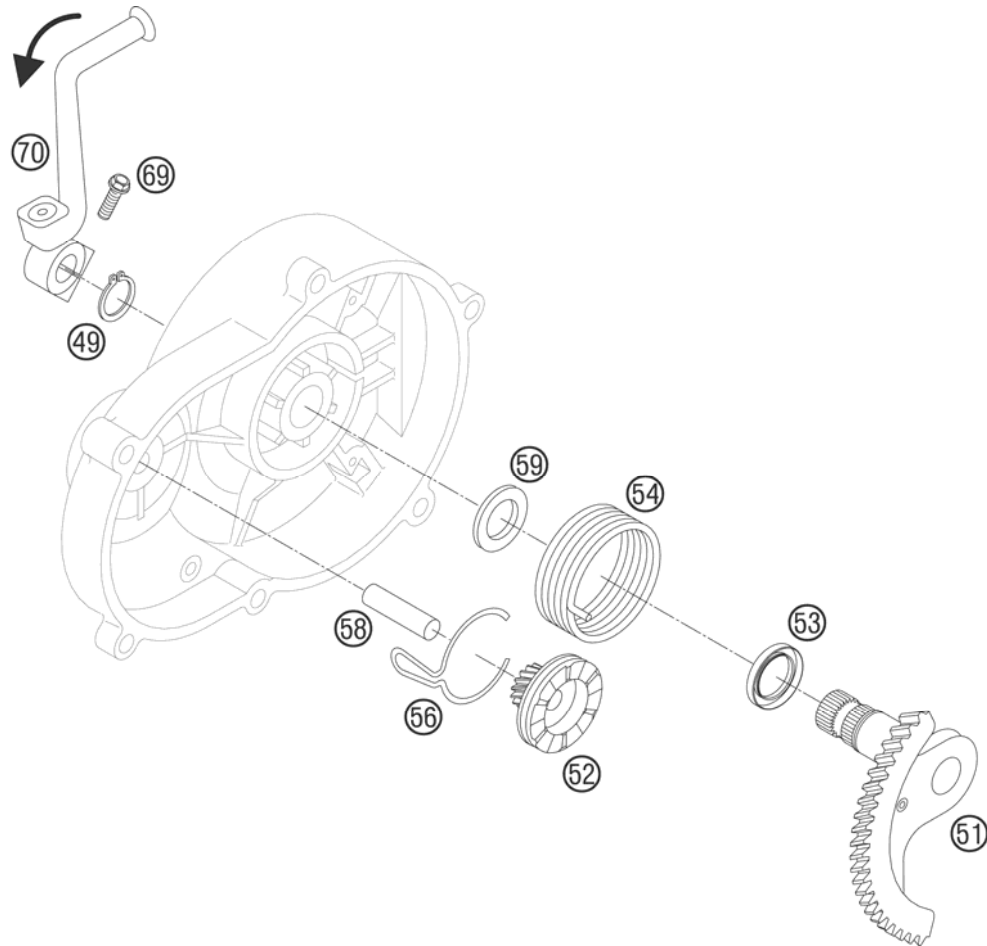
9

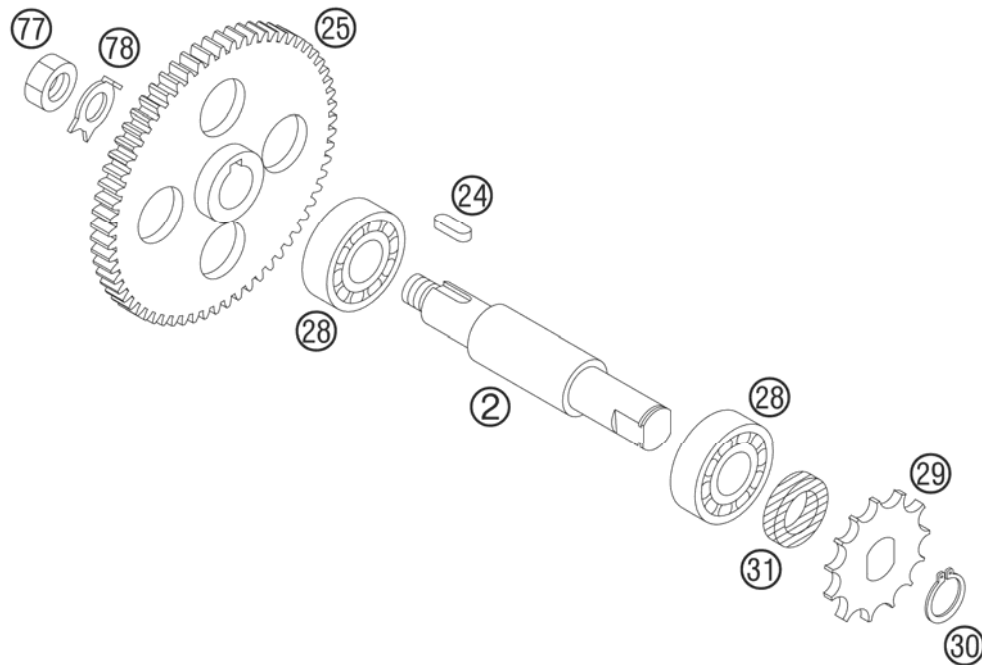

IGNITION SYSTEM

50 AC 2006

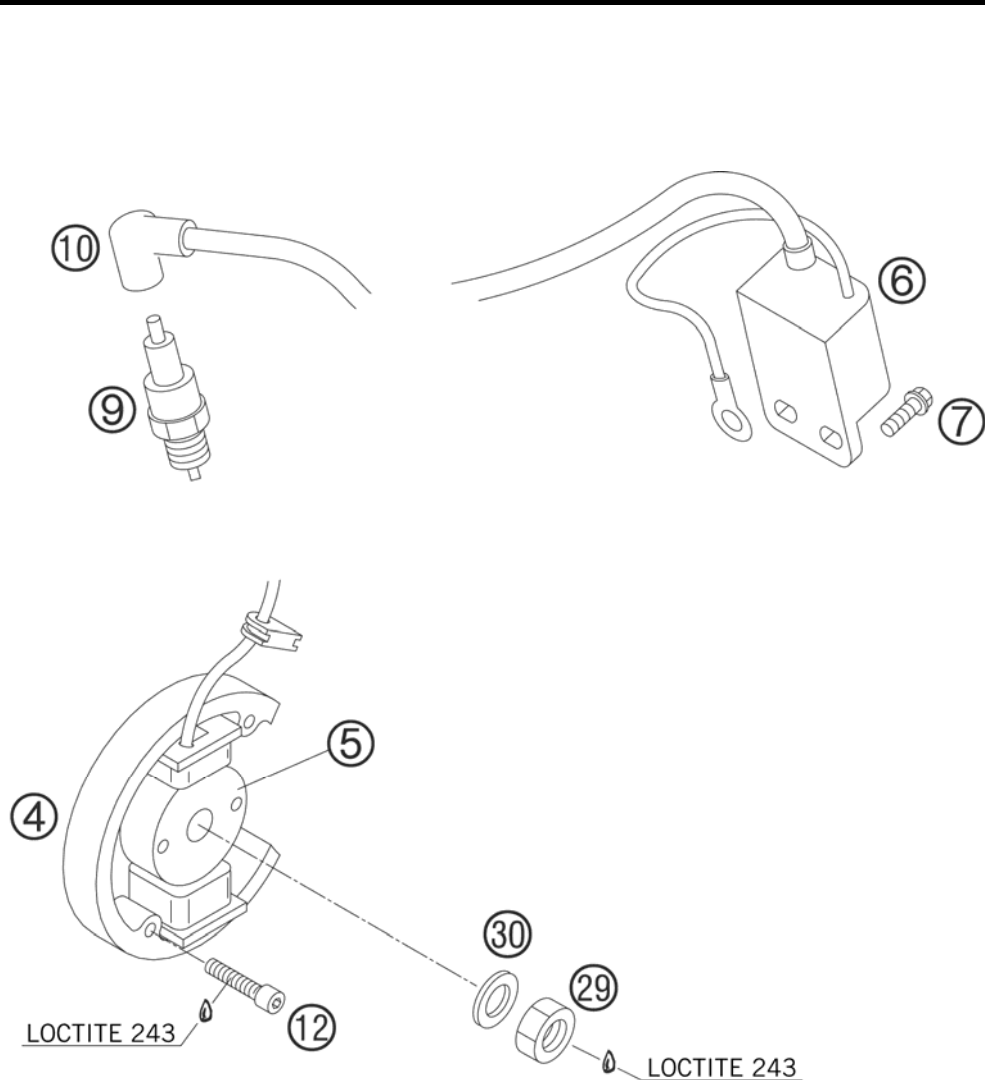

FIG	PART NUMBER	DESCRIPTION	QTY
4	45139004000	FLYWHEEL STATOR 50CCM LC 2001	1
5	45139005100	FLYWEEL ROTOR 50 2004	1
6	45139006000	IGNITION COIL 50CCM LC 2001	1
7	0015060123	HH COLLAR SCREW M 6X12 WS=8	2
9	54331093410	SPARK PLUG NGK BR8ECM	1
10	47039090000	SPARK PLUG CAP NGK REINFORC.04	1
12	0912050253	AH SCREW DIN0912-M 5X25	2
29	45130028000	SPECIAL NUT M10X1,25X6	1
30	45132020000	WASHER 10,4X16,8X0,4	1

064503901 / C064503901

* NEW PART

X AS REQUIRED

10



NOTICE

50 AC 2006

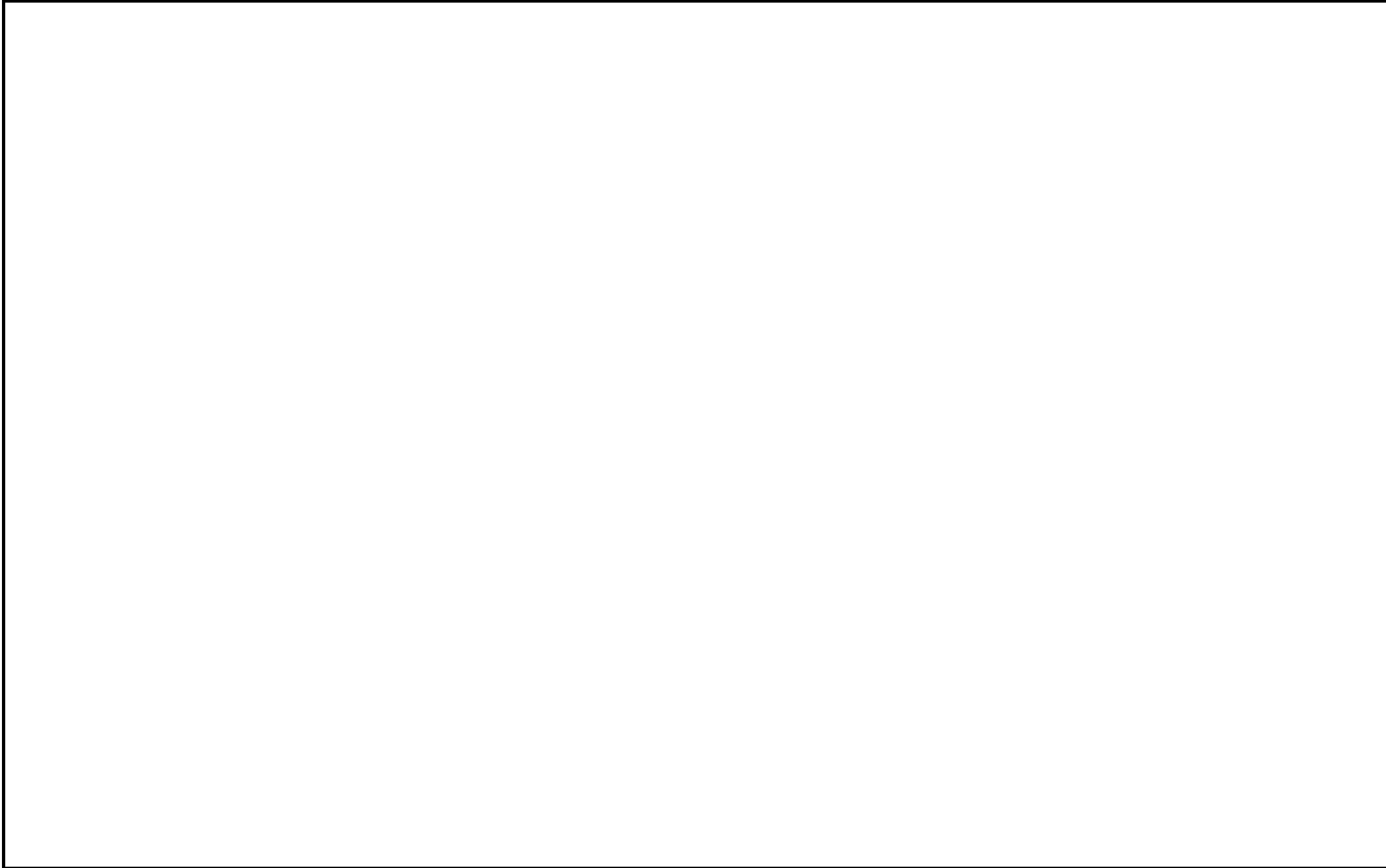



KTM Group Partner



3CM080233EN



KTM-Sportmotorcycle AG
A-5230 Mattighofen
www.ktm.at

Art.Nr.: 3CM080233EN 6/2005